

## TNC2000 System Overview

### Application

The TNC2000 machine protection and condition monitoring system provides continuous operational supervision of rotating machinery such as turbosets, compressors, blowers, exhaust fans, pumps, gears and others.

The system is based on the measurements of shaft axial position in thrust bearing, shaft differential thermal expansion, case absolute thermal expansion, bearing case absolute vibration, shaft relative vibration, valve position and phase angle/rotating speed.

Applied to protection and monitoring task the System provides binary signals, standard DC 4-20mA signals and serial digital interface RS485 with Modbus RTU or TCP/IP protocol to communicate with process control system for machine protection and visualisation purposes.

Expanded with diagnostic part the System provides continuous data acquisition and data storing in data base and Ethernet interface for communication with diagnostician work station through LAN plant network. The data acquisition software is installed on Data Acquisition Unit JAD, and diagnostic software SMMturbo have to be installed on each diagnostician work station (PC class computer). Using a FTP server equipped with additional software and protected by fire wall a remote monitoring made by outer diagnostic centre is possible.

The system continuously measures and monitors supervisory parameters. This provides crucial information of machinery problems such as:

- High synchronous vibration
- Shaft bow
- Shaft crack
- Fluid induced instabilities
- Rotor rub
- Loose parts
- Sleeve bearing failures
- Radial preloads forces (internal and external including misalignment)

### Description

All system devices and a system as whole unit are developed according to standards API670, ISO 10817, ISO2954, ISO7919, ISO10816 and other, thanks to what there is a possibility of co-operation with different process control systems.

TNC2000 system is composed of a wide range of different elements which can be divided into following groups:



- sensors and transducers
- electronic modules – monitors, power supply, local multi-channel display, data acquisition unit
- mechanical casings – 19" rack, 19" cabinet
- mechanical auxiliaries – feed through, fitting, sensor holders
- data acquisition and diagnostics software

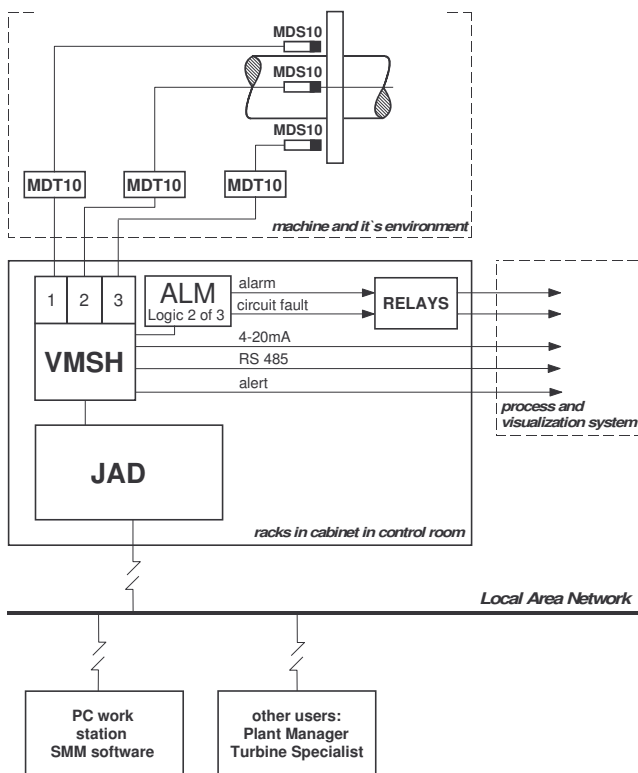
The sensors and transducers group used by TNC2000 system consists of:

- eddy – current sensors/transducers for non – contacting (proximity) measurements of axial position, thermal relative expansion, relative vibrations and phase angle/rotating speed
- eddy – current contacting sensors for casing expansion and valve position measurements
- electro-dynamical seismic sensors for absolute vibration velocity measurement
- piezoelectric sensors for absolute vibration acceleration or velocity measurement (accelerometers and piezo-velocity sensors)

Typical configurations of measurement circuits based on the TNC2000 equipment are shown at figures 1 to 8.

Thrust position measurements provides early warning of thrust bearing failure. The configuration according to figure1 shows rotor shaft axial position (at thrust bearing) measurement in case when the cylindrical collar or the free shaft end are very close to thrust bearing. Then the applied sensor is MDS10 with MDT10 transducer. Ideally, the probe is installed to observe the thrust collar directly, so the measurement represents the position of the collar relative to the thrust bearing clearance. In case of critical machines (turbogenerators, compressors) the axial position measurement is accomplished by two or three sensors to reach the highest reliability of the protection. The binary output to stop the machine in case of failure is then generated by alarm logic module ALM according to logic routine "2 of 3" or "2 of 2".

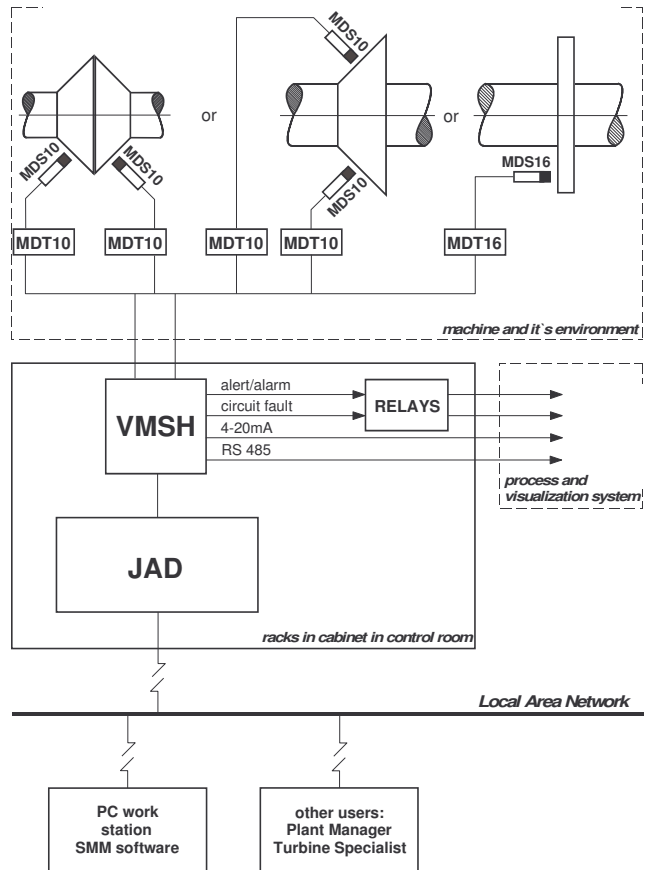




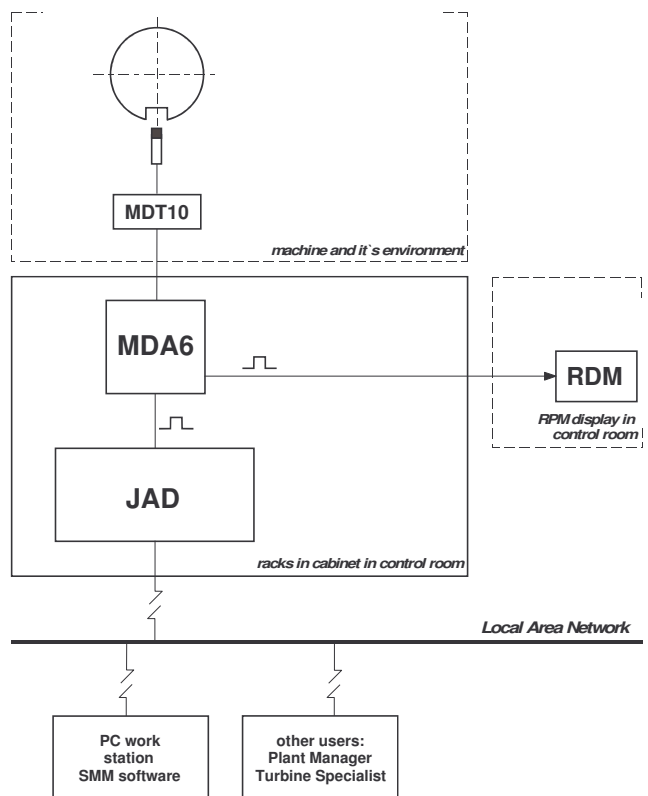
**Fig.1 Shaft thrust position**

To protect rotor steam labyrinth seal the thermal relative rotor expansion is measured (figure 2) – the difference between absolute casing expansion and absolute rotor expansion. In this case the applied probe /transducer is MDS16/MDT16 for 8mm range or MDS30/MDT30 for 12(16mm)mm range when cylindrical collar is accessible. In case of tapered or double tapered shaped collar the MDS10/MDT10 sensor system is used.

The circuit according to figure 3 shows rotating speed measurement realized by MDS10 sensor observing the mark(groove) on shaft surface. The signal from MDT10 transducer is conditioned by MDA5 monitor and then can be used in two ways: for displaying the rpm in control room using the rotating speed meter RDM and for diagnostics to provide the one per revolution pulse used for phase angle measurement of vibration spectral harmonics .

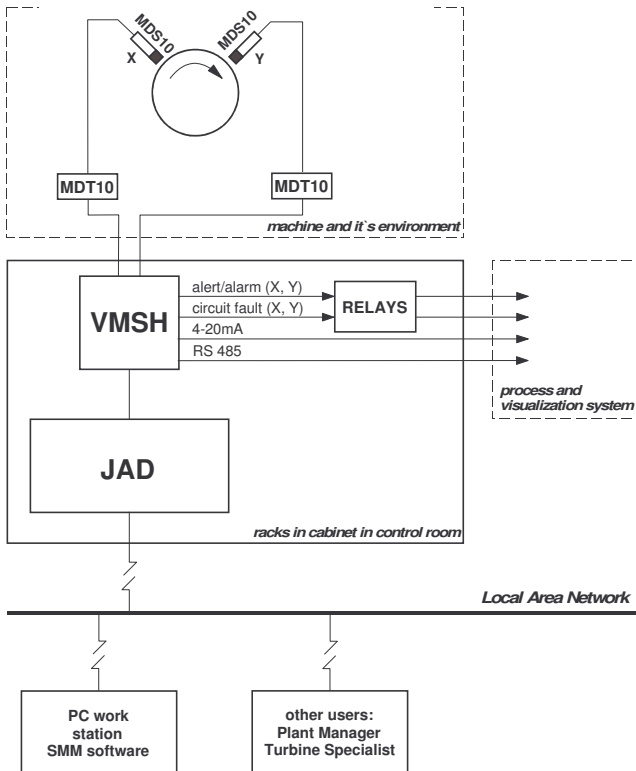


**Fig. 2 Shaft differential expansion**



**Fig. 3 Rotating speed and phase marker**





**Fig. 4 Radial displacement – relative vibration**

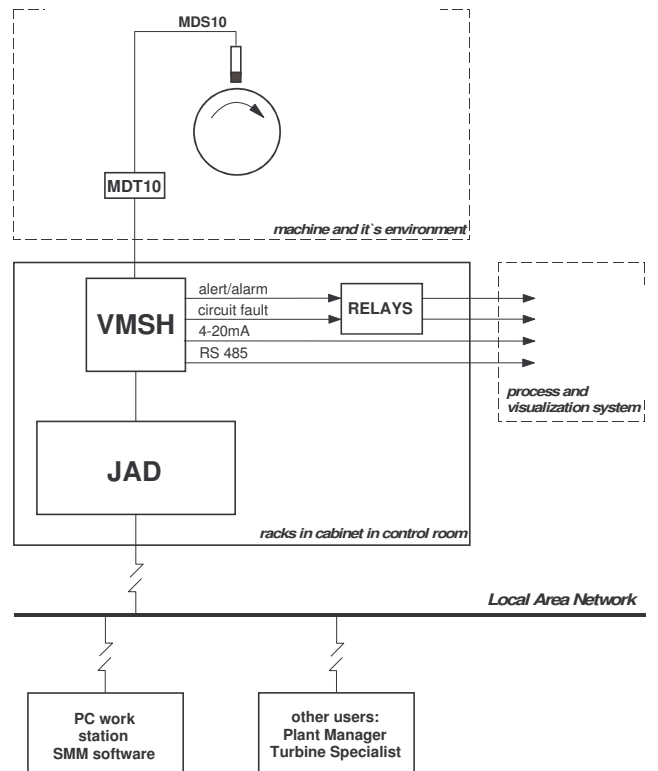
The circuit according to figure 4 contains two MDS10 sensors fixed mutually perpendicular and cooperating with the VMSH monitor configured for relative vibration monitor. This configuration indicates the dynamic motion of the shaft relative to the bearing. Figure 4 shows some of the more common techniques for employing this non-contacting measurements. In case of relative vibration measurements two probes should be installed per bearing to provide determining of shaft trajectory. The application of several circuits according to figure 4 make possible to determine the shaft deflection line. VMSH monitor inform of the exceeding of the relative vibration limit values in both measuring axis and of exceeding the  $S_{max}$  limit value (ISO7919 standard).

The eccentricity measuring circuit( figure 5) is very important to conduct the machine with flexible rotor(like turbogenerator) through the critical rotating speed to machine’s nominal speed. It protects the machine from rotor’s rubs to non rotating parts.

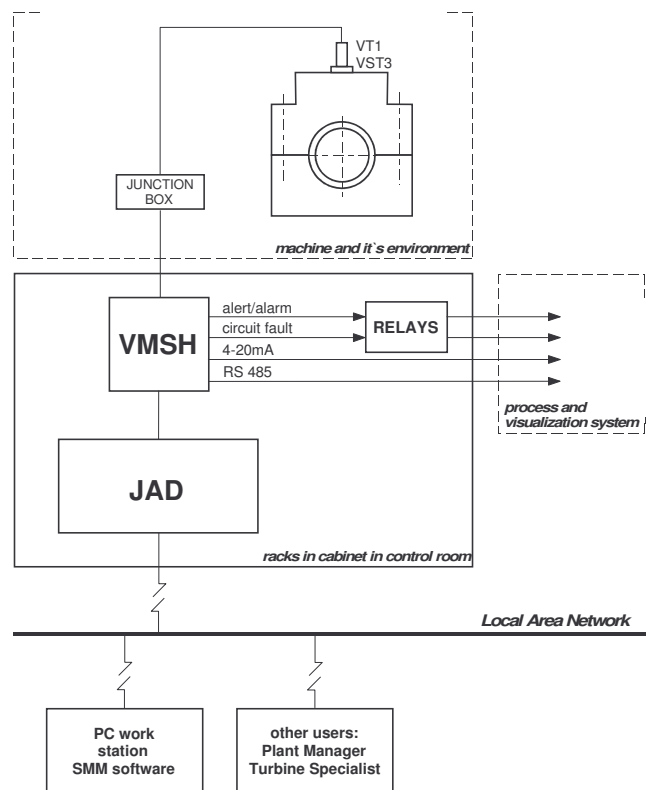
The absolute vibration measurement of bearing housing in one direction is shown at the figure 6. To provide this type of measurement two types of sensors can be used:

- vibration velocity sensors: piezoelectric type VT1 or electrodynamical type VST3 preferred for machines with slide bearings
- vibration acceleration sensors: AT2/100 with integral cable or AT3/100 with cable connected by connector preferred for machines with ball bearings.

VMSH monitor provides output signals proportional to the RMS or Peak values of chosen vibration estimation: acceleration or velocity.



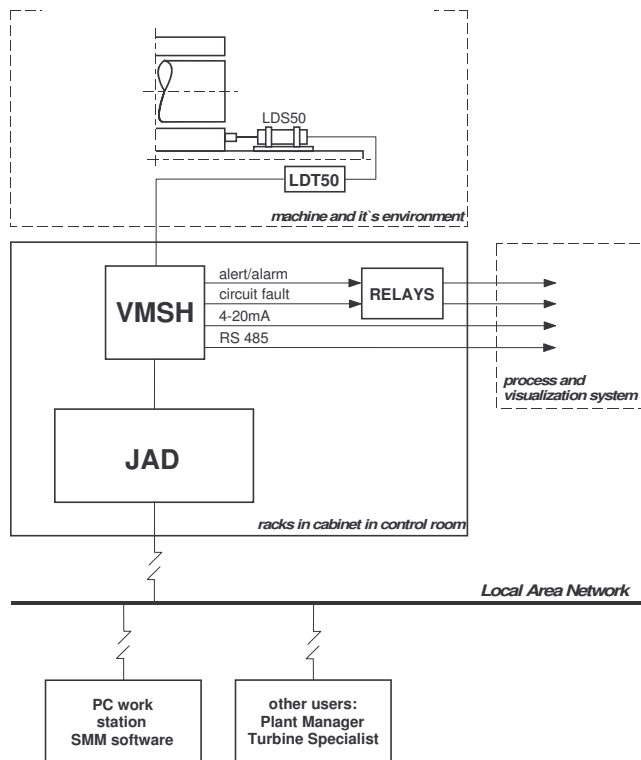
**Fig. 5 Shaft eccentricity**



**Fig. 6 Bearing housing absolute vibration**

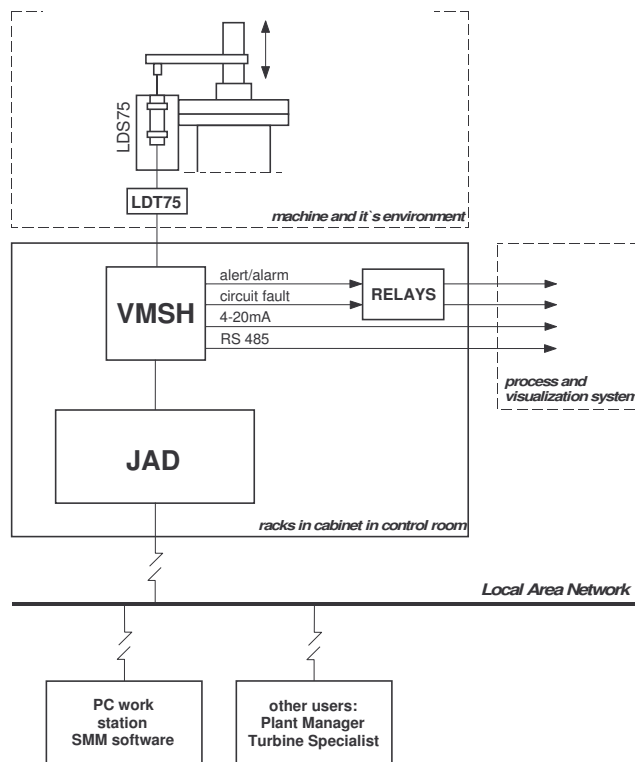


In case of critical machines – important because of it's participation in technological process or because of heavy losses caused by unplanned machine shut down – a standard is application of two absolute vibration circuits on one bearing in two orthogonal directions (horizontally and vertically).



**Fig.7 Absolute case expansion**

The configuration according to figure 7 and 8 shows the implementation of eddy-current contact sensors of LDS/LDT series. At fig.7 the measurement of casing thermal expansion in relation to foundation and at fig.8 the measurement of valve position. In depend on required range different models of LDS/LDT system can be used.

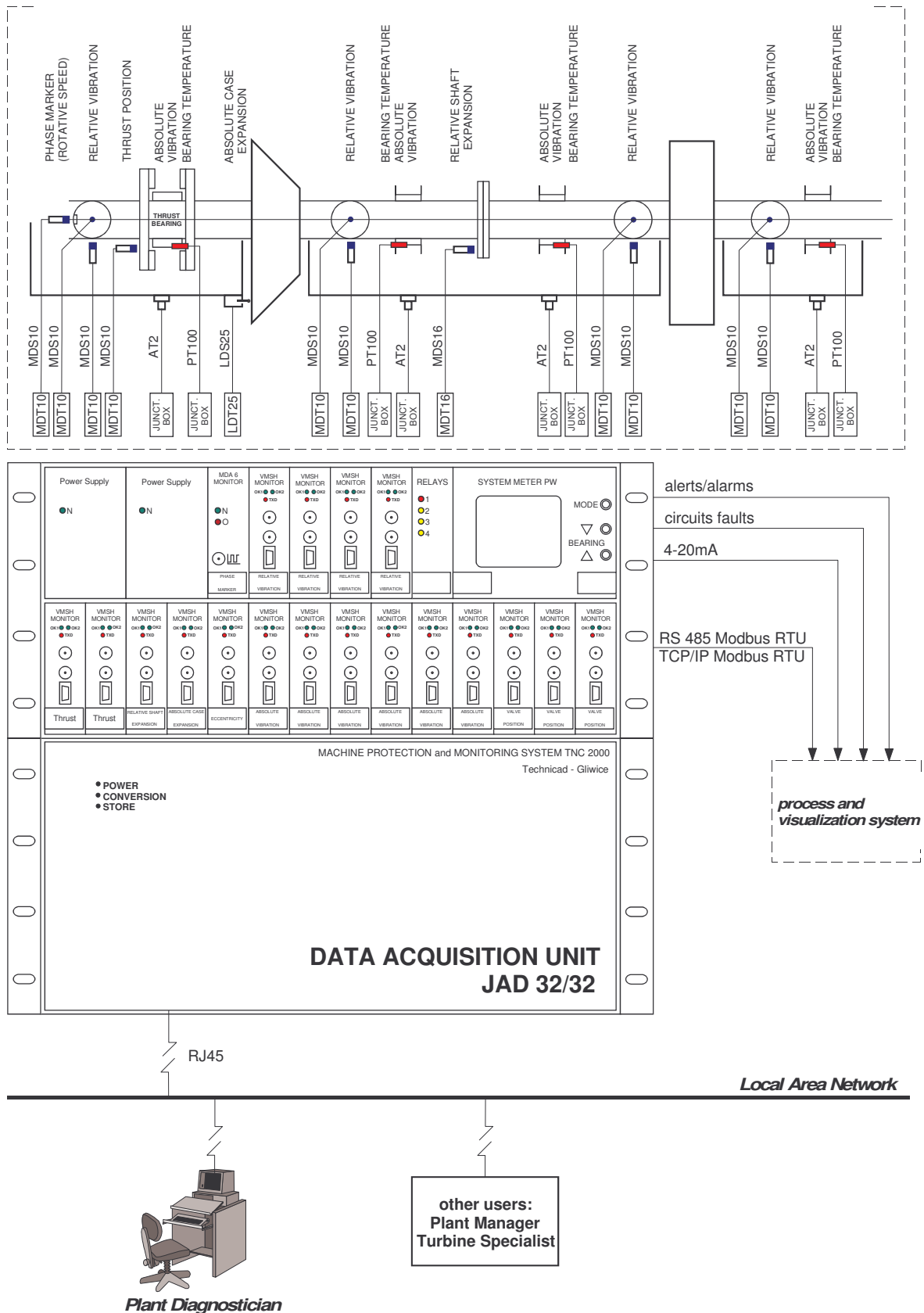


**Fig.8 Valve position**

All system monitors are mounted in a 19" rack of 3U (ca 130mm) height. In depend of circuits amount the system can occupy space of one or more racks. Racks are mounted in cabinet. One or two power supplies can be installed in the rack. Two power supplies are connected in redundant way. In case of fault one of them, the other take over all power load. The power supply module can be changed on-line.

In case of local display requirement the rack can be equipped with multichannel system meter PW. Each measuring channel generates two alert/alarm binary outputs of limit value exceeding and one binary output of channel fault. For better reliability the channells generating alarms for machine shut down can be doubled or tripled and in cooperation with alarm logic module ALM the machine shut down will be made according to „2 of 3“ or „2 of 2“ logic procedure.





**Fig. 9 Configuration and elements location for TNC2000 system application**